



Provincial Mathematics Assessment at Grade 5

English Prime

Sample Assessment

2011



PROVINCIAL ASSESSMENT PROGRAM

Provincial Mathematics Assessment Program: Information Bulletin

February, 2011

Assessment and Evaluation Branch
Department of Education and Early Childhood Development
Province of New Brunswick
P.O. Box 6000
Fredericton, N.B.
E3B 5H1
Canada

www.gnb.ca/education

For the teacher

Information Regarding the Provincial Mathematics Assessment at Grade 5

All elementary assessments will take place from May 26th to June 2nd, 2011. In response to teacher feedback, the Provincial Mathematics Assessment at Grade 5 will consist of three separate parts which can be administered on a flexible schedule at any time during the elementary administration schedule (please note: the content has not increased). The general layout of the assessment will be as follows:

Grade 5
Part A: <i>Mental Math</i> <i>Multiple Choice</i>
Part B: <i>Mental Math</i> <i>Multiple Choice</i>
Part C: <i>Basic Facts (separate sheet)</i> <i>Constructed Response</i>

To assist teachers and to ensure consistent administration, all teachers will use the *Teacher Guide* in the administration of the May/June assessment. Every teacher will receive the *Teacher Guide* along with each class set of assessment booklets.

Answer Sheets (bubble sheets) are no longer required for the grade 5 provincial assessment.

All items within the mathematics assessments are aligned to the New Brunswick Mathematics Curriculum. The following sample assessment is provided to illustrate the questions and test formatting and is not, in any way, meant to be a comprehensive representation of the assessment.

For further information on the Mathematics Assessment at Grade 5, please see the 2011 Mathematics Information Bulletin located on the portal on the Assessment and Evaluation site: <https://portal.nbed.nb.ca/tr/AaE/Pages/default.aspx>

NB: Part A is provided as a rough guide for timing. Part B of the May/June assessment has a similar layout and number of questions.

This page is intentionally blank

Provincial Mathematics Assessment at Grade 5

Sample Assessment Part A

Solve the following questions by filling in the bubble of the correct answer.

3. How many hundreds make two thousands?

- Ⓐ 2
- Ⓑ 20
- Ⓒ 200
- Ⓓ 2000

4. Which is the same as 16×25 ?

- Ⓐ 32×50
- Ⓑ 8×100
- Ⓒ 4×50
- Ⓓ 4×100

5. A pyramid has 6 faces. What does the base look like?

- Ⓐ a triangle
- Ⓑ a square
- Ⓒ a pentagon
- Ⓓ a hexagon

6. Scott designed a spinner on which spinning red is more likely than spinning green, but spinning red is less likely than spinning yellow. Which spinner did he design?

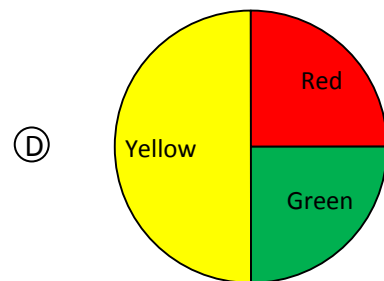
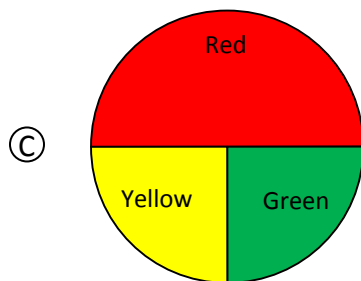
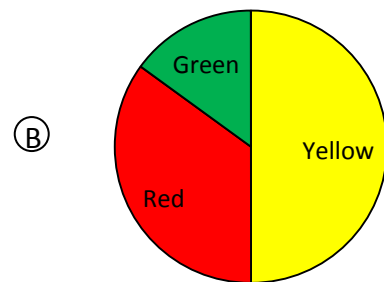
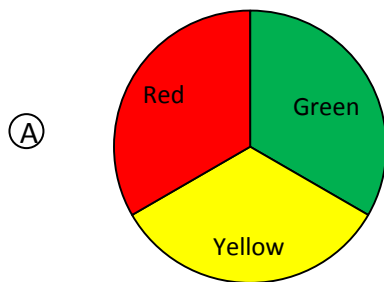

7. Karen saves \$18.75 each week. What is the best estimate of how much Karen will save after 6 weeks?

Ⓐ \$40

Ⓑ \$80

Ⓒ \$120

Ⓓ \$160

8. 257 m is equal to

Ⓐ 257 000 cm

Ⓑ 0.257 km

Ⓒ 2570 mm

Ⓓ 2.57 km

9.

Riverview School

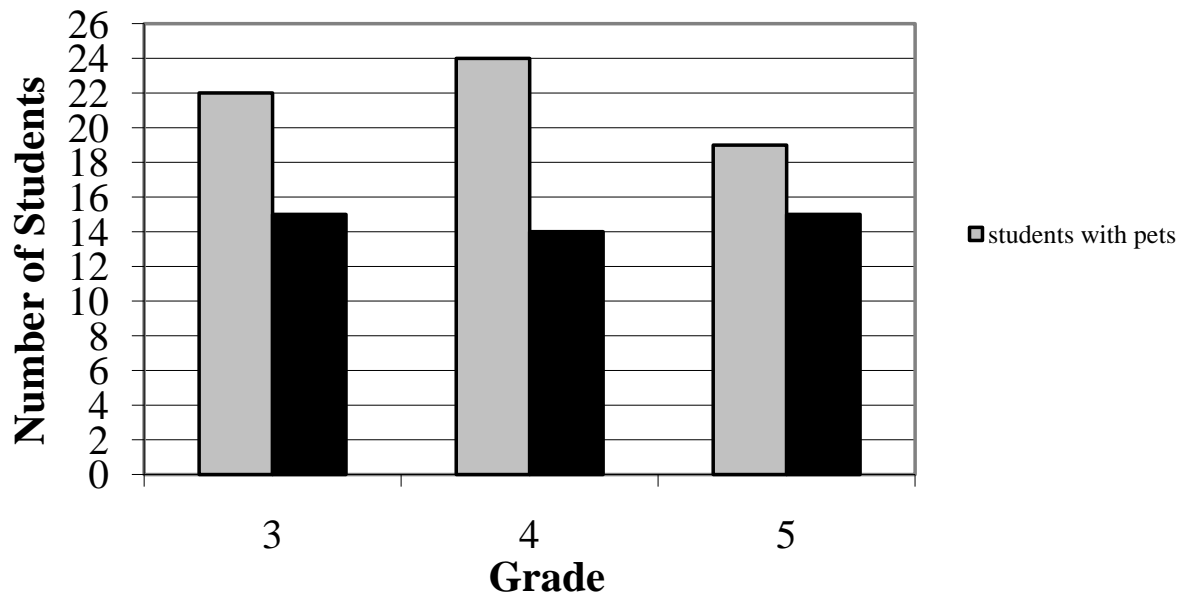

More students have pets than those who do not. How many more?

- (A) 18
- (B) 19
- (C) 20
- (D) 21

10. $12 - 0.37 =$

Ⓐ 11.63

Ⓑ 0.25

Ⓒ 11.73

Ⓓ 12.25

11. Pierre plants flowers in trays that hold 8 plants. What is the best estimate for the number of trays needed to plant 950 plants?

Ⓐ 80

Ⓑ 120

Ⓒ 200

Ⓓ 4000

12. Which of the following rectangles has a perimeter of 14 cm and an area of 12 cm² (shapes not drawn to scale)?

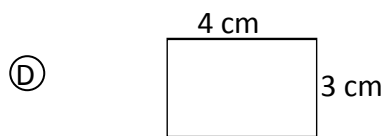
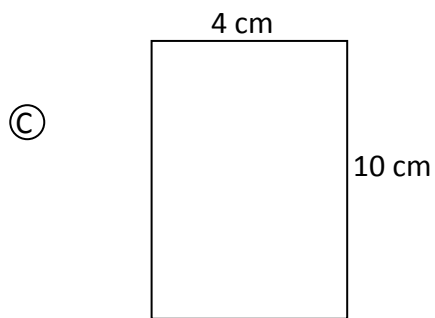
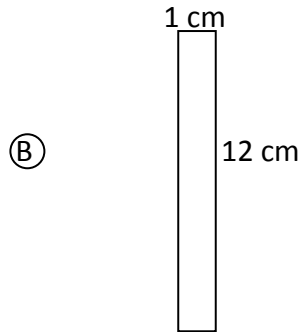
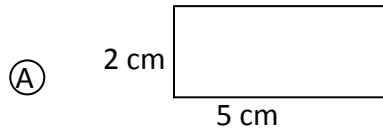

13. Which is always true if \square is an odd number?

Ⓐ $6 \times \square = \text{an even number}$

Ⓑ $\square + \square = \text{an odd number}$

Ⓒ $\square - \square = \text{an odd number}$

Ⓓ $4 - \square = \text{an even number}$

14. Which answer is about 60?

Ⓐ $4779 \div 79 =$

Ⓑ $1434 \div 19$

Ⓒ $1286 \div 31$

Ⓓ $5400 \div 99$

15. The length of a rectangle is 10 cm. Its area is 50 cm^2 . What is its perimeter?

- Ⓐ 30 cm
- Ⓑ 40 cm
- Ⓒ 60 cm
- Ⓓ 500 cm

16. Bob wanted to know how much rain fell in November. Which of the following is an example of collecting second-hand data?

- Ⓐ searching online
- Ⓑ measuring the amount of rainfall in one day and multiplying by 30
- Ⓒ measuring the amount that he collected in a rain bucket
- Ⓓ estimating the depth of water in a puddle

17. Which of these numbers has the most factors?

(A) 12

(B) 13

(C) 24

(D) 25

Use the following diagram to answer question 18.

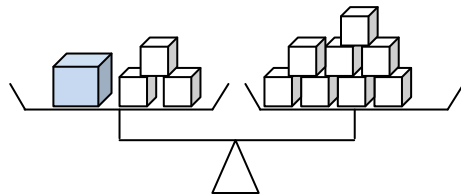

18. (A) $4p = 8$

(B) $3p + 1 = 8$

(C) $8 = 3p - 1$

(D) $8 = p + 3$

19. Which fraction is between $\frac{2}{5}$ and $\frac{7}{10}$?

Ⓐ $\frac{3}{10}$

Ⓑ $\frac{1}{2}$

Ⓒ $\frac{3}{4}$

Ⓓ $\frac{4}{5}$

20. I have two sets of parallel sides. All my sides are equal. Two of my angles are greater than a right angle and two are smaller than a right angle. What am I?

- Ⓐ rectangle
- Ⓑ trapezoid
- Ⓒ square
- Ⓓ rhombus

21. You have \$50. You buy jeans for \$41.99. What is your change?

- Ⓐ \$91.99
- Ⓑ \$8.01
- Ⓒ \$9.99
- Ⓓ \$9.01

Provincial Mathematics Assessment at Grade 5 Basic Facts Assessment

General Instructions

- There are 15 basic facts questions.
- You will have 1 minute to answer all of the questions.
- Write the answer to each question on the line provided.

Put your finger on the sample question.
Read the question to yourself.
The correct answer is 5. Write the answer on the
line next to the question.



Practice Question

$$3 + 2 = \underline{\hspace{2cm}}$$

Please do not turn the page until told to do so.

Basic Facts Grade 5 Sample

1. $4 \times 5 =$ _____
2. $32 \div 4 =$ _____
3. $7 \times 8 =$ _____
4. $42 \div 7 =$ _____
5. $18 \div 3 =$ _____
6. $0 \times 8 =$ _____
7. $56 \div 7 =$ _____
8. $6 \times 6 =$ _____
9. $64 \div 8 =$ _____
10. $3 \times 8 =$ _____
11. $7 \div 1 =$ _____
12. $6 \times 9 =$ _____
13. $8 \div 8 =$ _____
14. $9 \times 9 =$ _____
15. $72 \div 9 =$ _____

Provincial Mathematics Assessment at Grade 5

Sample Assessment Part C

This page is intentionally blank

INSTRUCTIONS FOR STUDENTS:

This section has questions that ask for written answers. Answer each question completely and remember to show all of your work.

Ron would like to make birdhouses to sell at the local market. He designs his birdhouses to look like this:

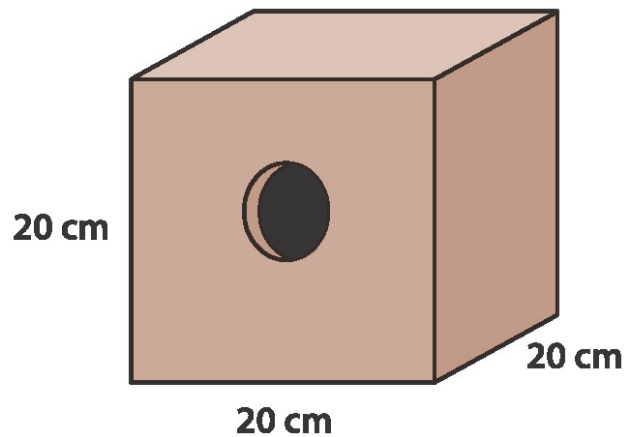

His friend Sylvia gives him a piece of plywood that is 2 metres by 1 metre.
How many birdhouses can he make with this sheet of plywood?

Grades 3, 4 and 5 students completed an entertainment survey. The following information was collected showing the different type of entertainment preferred by the students surveyed.

Grade	TV	Video
3	66	9
4	51	24
5	35	40

What does this information tell us about the entertainment preferences of students? Support your answer with charts and/or diagrams.

